

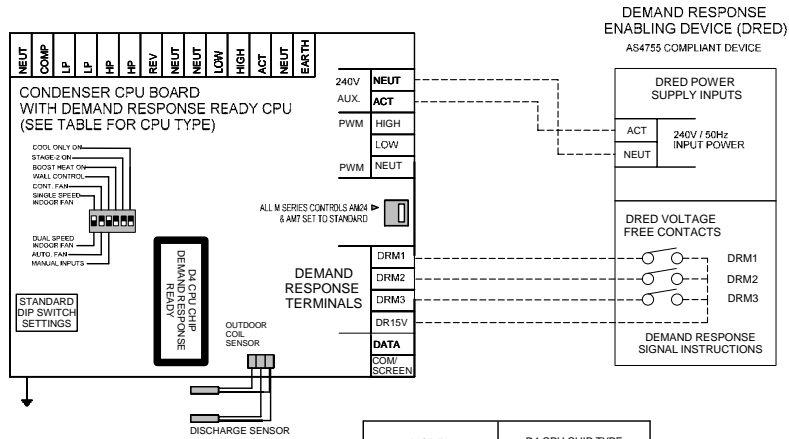

WIRING DIAGRAM FOR R410a & R22 STANDARD & DIGITAL FITTED WITH DEMAND RESPONSE READY RETROFIT KIT INSTALLED  
**R410a STANDARD / DIGITAL R22 STANDARD / DIGITAL DEMAND RESPONSE READY RETROFIT KIT**

REV.	DATE	DRAWING No.
A	16/09/2008	WD0478

This drawing remains the intellectual property of Actron Engineering Pty Ltd. Reproduction, modification and/or distribution are prohibited without written consent.



MODEL	D4 CPU CHIP TYPE
R410A STANDARD	P210P STANDARD
R410A DIGITAL	P311P DIGITAL
R22 STANDARD	D411P STANDARD
R22 DIGITAL	D103P DIGITAL

**DEMAND RESPONSE READY AIR CONDITIONER:**

This is a Demand Response Ready Air Conditioner compliant with Australian Standards AS4755.3.

When fitted with an appropriate Demand Reponse Enabling Device (DRED) this Air Conditioner may automatically enter a Demand Response Mode at any time.

When Air Conditioner is running in a Demand Response Mode, the ON/OFF LEDs on the Main CPU Board will flash alternatively.

**DEMAND RESPONSE OPERATING MODES:**

DEMAND MANAGEMENT MODE	DESCRIPTION OF MODE	MODEL	OPERATING MODE
DRM1	COMPRESSOR OFF	STANDARD	Compressor ONLY will Cycle OFF & remain off for the entire Demand Response Event.
		DIGITAL	
DRM2	MAXIMUM 50% INPUT POWER USE MODE. (OVER EACH 1/2 HOUR PERIOD)	STANDARD	Compressor will turn off for 17 minutes then back on as required for the next 13 minutes – repeating this cycling rate for the total Demand Response Event.
		DIGITAL	Digital Compressor will Run at < 50% PWM Modulation continuously during the total Demand Response Event.
DRM3	MAXIMUM 75% INPUT POWER USE MODE. (OVER EACH 1/2 HOUR PERIOD)	STANDARD	Compressor will turn off for 9 minutes then back on as required for the next 21 minutes – repeating this cycling rate for the total Demand Response Event.
		DIGITAL	Digital Compressor will Run at < 75% PWM Modulation continuously during the total Demand Response Event.

DESIGNS AND SPECIFICATIONS ARE SUBJECT TO CHANGE WITHOUT NOTICE.



WIRING DIAGRAM FOR R410a & R22 STANDARD & DIGITAL FITTED WITH DEMAND RESPONSE READY RETROFIT KIT INSTALLED  
**R410a STANDARD / DIGITAL R22 STANDARD / DIGITAL DEMAND RESPONSE READY RETROFIT KIT**

REV.	DATE	DRAWING No.
A	16/09/2008	WD0478

This drawing remains the intellectual property of Actron Engineering Pty Ltd. Reproduction, modification and/or distribution are prohibited without written consent.

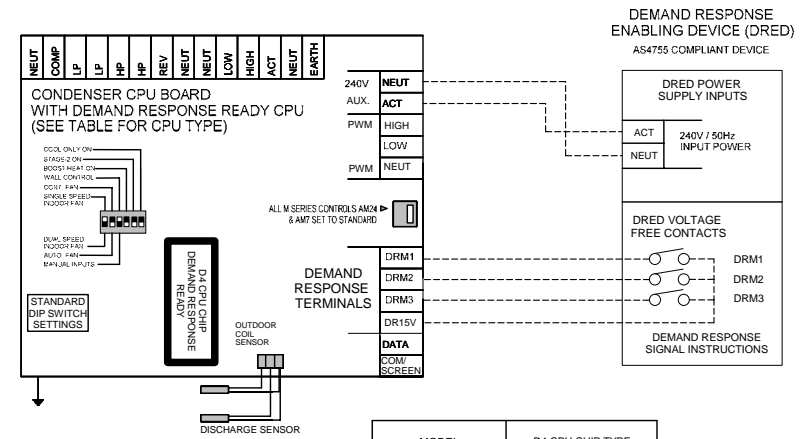

MODEL	D4 CPU CHIP TYPE
R410A STANDARD	P210P STANDARD
R410A DIGITAL	P311P DIGITAL
R22 STANDARD	D411P STANDARD
R22 DIGITAL	D103P DIGITAL

**DEMAND RESPONSE READY AIR CONDITIONER:**

This is a Demand Response Ready Air Conditioner compliant with Australian Standards AS4755.3.

When fitted with an appropriate Demand Reponse Enabling Device (DRED) this Air Conditioner may automatically enter a Demand Response Mode at any time.

When Air Conditioner is running in a Demand Response Mode, the ON/OFF LEDs on the Main CPU Board will flash alternatively.

**DEMAND RESPONSE OPERATING MODES:**

DEMAND MANAGEMENT MODE	DESCRIPTION OF MODE	MODEL	OPERATING MODE
DRM1	COMPRESSOR OFF	STANDARD	Compressor ONLY will Cycle OFF & remain off for the entire Demand Response Event.
		DIGITAL	
DRM2	MAXIMUM 50% INPUT POWER USE MODE. (OVER EACH 1/2 HOUR PERIOD)	STANDARD	Compressor will turn off for 17 minutes then back on as required for the next 13 minutes – repeating this cycling rate for the total Demand Response Event.
		DIGITAL	Digital Compressor will Run at < 50% PWM Modulation continuously during the total Demand Response Event.
DRM3	MAXIMUM 75% INPUT POWER USE MODE. (OVER EACH 1/2 HOUR PERIOD)	STANDARD	Compressor will turn off for 9 minutes then back on as required for the next 21 minutes – repeating this cycling rate for the total Demand Response Event.
		DIGITAL	Digital Compressor will Run at < 75% PWM Modulation continuously during the total Demand Response Event.

DESIGNS AND SPECIFICATIONS ARE SUBJECT TO CHANGE WITHOUT NOTICE.