

8.8 KRP58M51 — Demand adaptor

KRP58M51

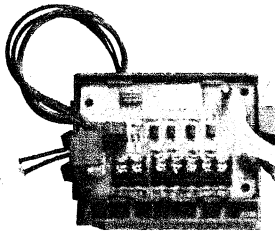

Installation

DEMAND ADAPTOR MOUNTING INSTRUCTIONS KRP58M51

WARNING If the warning is not observed, it may cause serious casualties.

Before installing this kit, turn off power switch. Do not turn on it until all work is complete. See the installation manual and the wiring diagram of the outdoor unit for installation work, too.

Accessories Check if the following accessories are included in the kit.

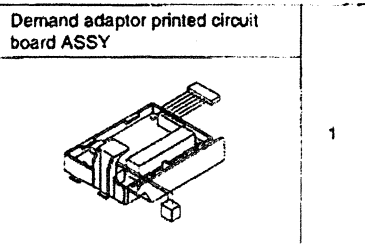

Tie wrap	x4
Fixing screw	x1
Installation manual	x1 (Each language)

1 SYSTEM OUTLINE

The following set up for outdoor unit can be done by this kit.

- (1) Demand control
- (2) Night quiet operation mode

2 NAMES OF PARTS AND FUNCTION

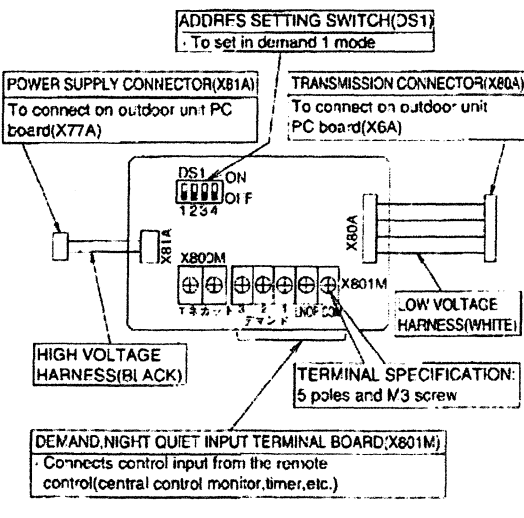

3 SETTING METHOD

(1) SETTING OF DEMAND RUNNING

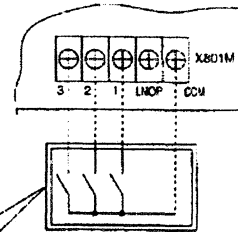

[INPUT SIGNAL]
Always a contactor
Input current is 12mA per contactor.
Please use small current contactor as input contactor.
Please use the minimum load of DC 12V, 1mA or less.

[FIELD WIRING SPECIFICATION]
Recommended wiring: sheathed vinyl cord or 2 wire cable 0.75 - 1.25mm² / AWG 18 - 16
Wiring length: 100m or less
Keep transmission wiring away from power supply wiring to avoid malfunction.

DEMAND 1 : Short circuit COM-1 ... guideline of (RZO type only) power consumption between 60 - 100%

DS1 SET POINT		DEMAND 1	
1	2	INPUT ON, POWER CONSUMPTION	
OFF	OFF		60% OF RATED POWER CONSUMPTION
ON	OFF		70% OF RATED POWER CONSUMPTION
OFF	ON		80% OF RATED POWER CONSUMPTION
ON	ON		100% OF RATED POWER CONSUMPTION

DEMAND 2 : Short circuit COM-2 ... guideline of power consumption at 40% (RZO type only)

DEMAND 3 : Short circuit COM-3 ... forced thermostat OFF

(2) SETTING OF NIGHT QUIET MODE

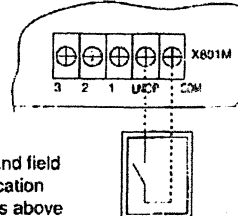

*Input signal and field wiring specification is the same as above

Short circuit between COM-LNOP on terminal (X801M) of demand adaptor. Low sound running to be done with limited outdoor fan speed, compressor running frequency (this model should be used with low load at night, etc.).

*Setting of auto mode, refer to field setting by remote controller (technical guide).

《RZQ71KBV4A》

- 1** Open the front panel, and take the demand adaptor printed circuit board from the demand adaptor case.

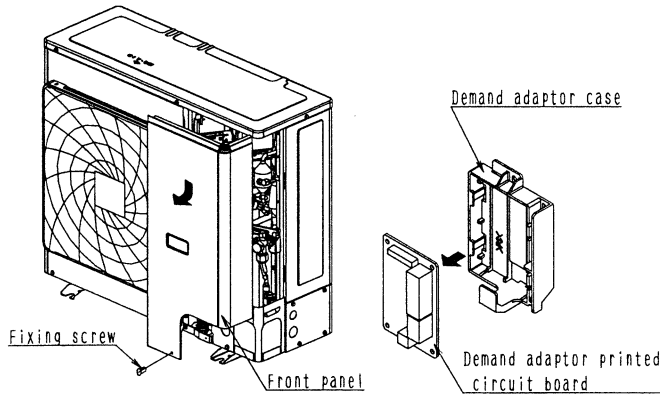

- 2** Mount the demand adaptor printed circuit board.

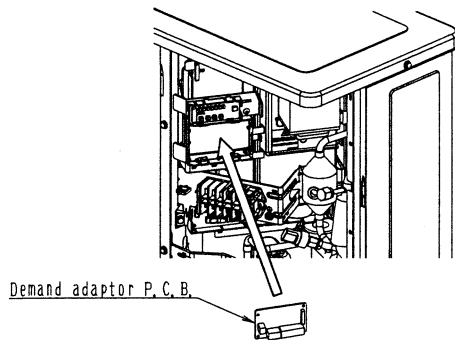

- 4** Fix the remaining low voltage harness (white) with clamp (accessory). Bind the remaining high voltage harness (black) with clamp (accessory) without slack.

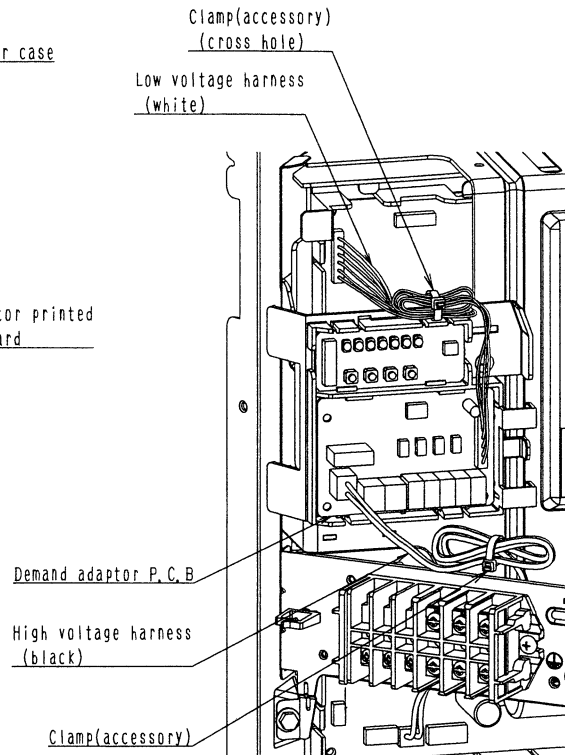

3

- 3** Transmission connector (X80A(white)) connect to P.C.B. control connector(X6A(white)) Power supply connector (X81A(white)) connect to P.C.B. control connector(X77A(yellow)) Pass the high voltage harness (black) through the back of terminal bed.

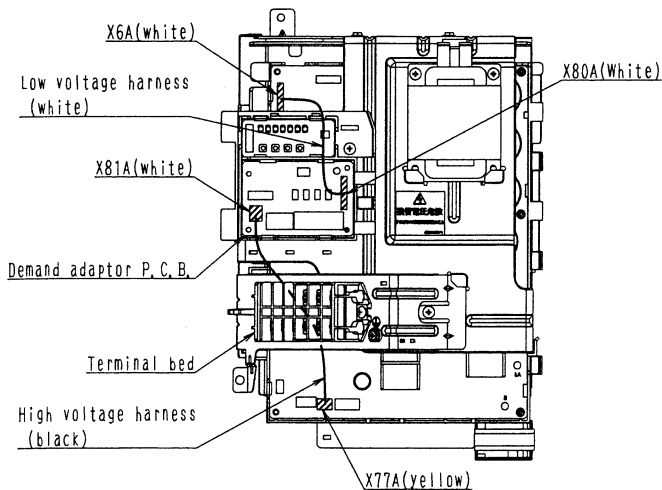

- 5** Pass the field wiring under the high voltage harness (black) and fix it with clamp (accessory).

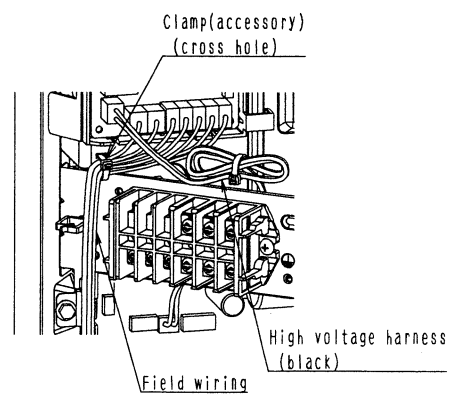

C:3P201377A

《RZQ100HY4A / RZQ125HY4A / RZQ160HY4A》

4 INSTALLATION METHOD

1

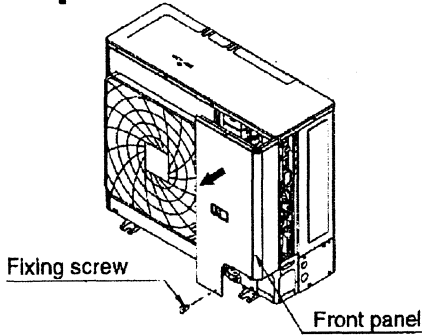

• Open the front panel.

5

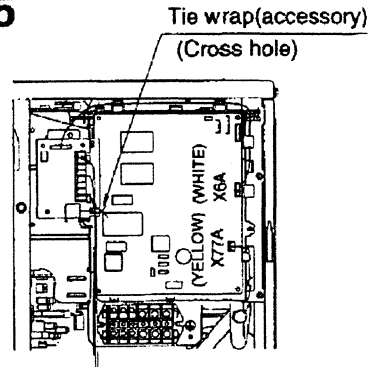

• Clamp the harness with tie wraps (accessory).

2

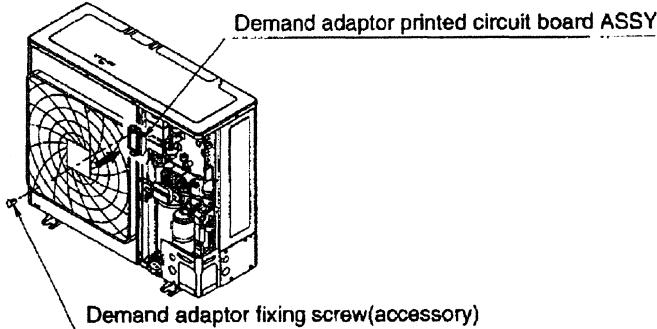

• Mount the demand adaptor printed circuit board ASSY.

3

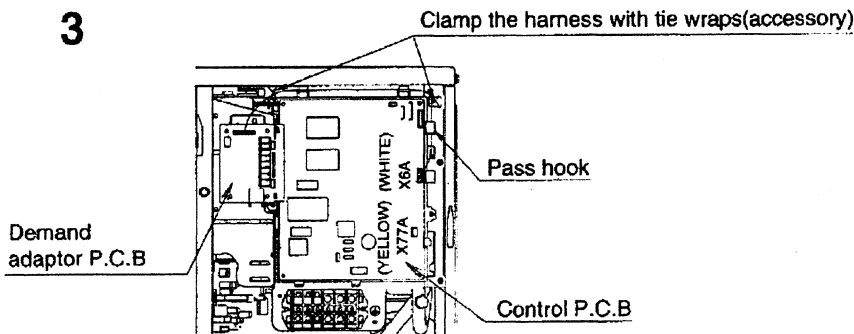

• Transmission connector (X80A) connect to P.C.B. control connector (X6A).

4

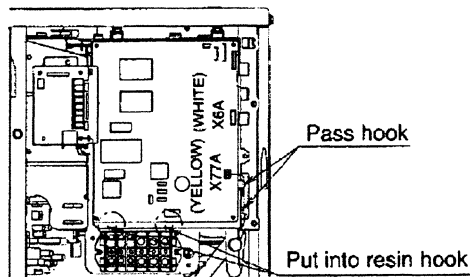

• Power supply connector (X81A) connect to P.C.B. control connector (X77A).

《RZQ100KV4A / RZQ125KV4A / RZQ160KV4A》

- 1** Open the front panel, and take the demand adaptor printed circuit board from the demand adaptor case.

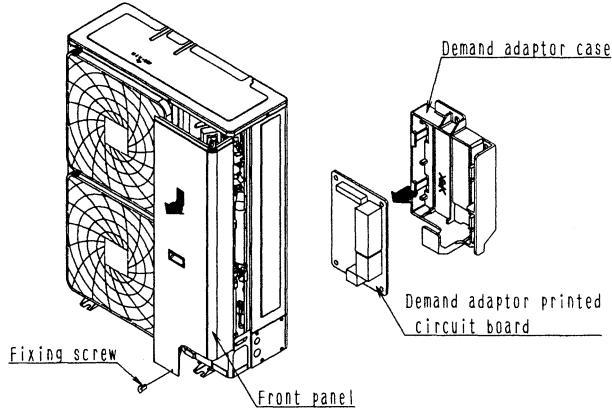

- 2** Mount the demand adaptor printed circuit board.

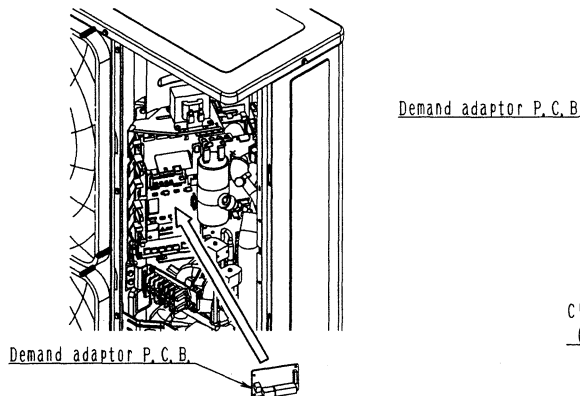

- 3** Transmission connector (X80A(white)) connect to P.C.B. control connector(X6A(white))
Power supply connector (X81A(white)) connect to P.C.B. control connector(X77A(yellow))

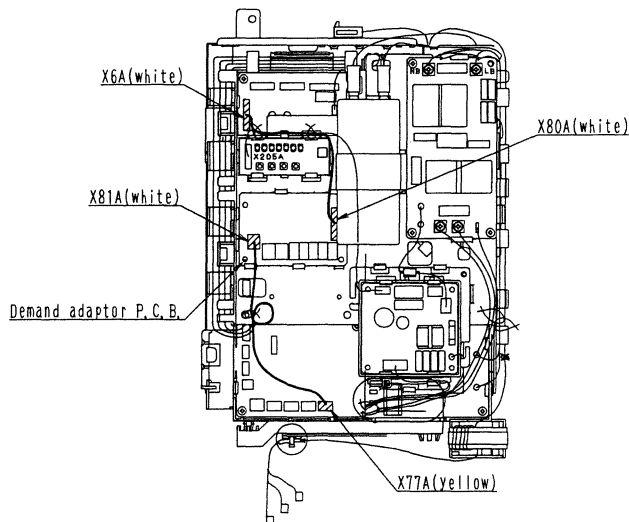

- 4** Fix the remaining low voltage harness (white) with clamp (accessory).
Fix the remaining high voltage harness (black) with clamp (accessory).

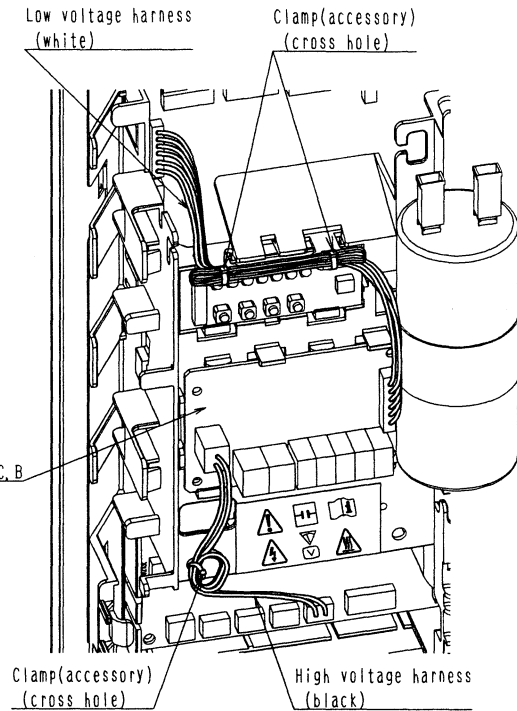

3

- 5** Fix the field wiring with clamp (accessory)

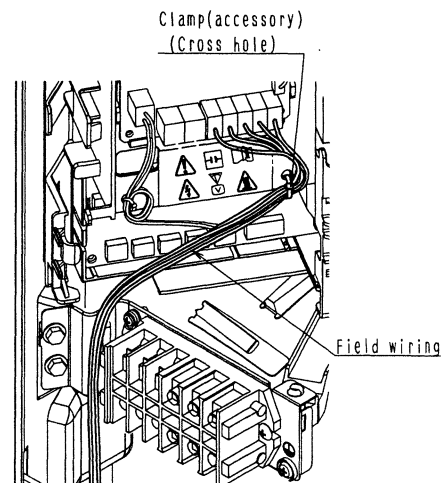

3P201377A