



AIR CONDITIONER OUTDOOR UNIT

 <h2>CAUTION</h2> <h3>R32 REFRIGERANT</h3> <p>This Air Conditioner contains and operates with refrigerant R32.</p> <p>THIS PRODUCT MUST ONLY BE INSTALLED OR SERVICED BY QUALIFIED PERSONNEL.</p> <p>Refer to Commonwealth, State, Territory and local legislation, regulations, codes, installation & operation manuals, before the installation, maintenance and/or service of this product.</p>
--

1. SAFETY PRECAUTIONS

- Read carefully all of safety information written in this manual before you install or use the air conditioner.
- The warnings and precautions indicated in this manual contain important information pertaining to your safety. Be sure to observe them.
- Hand this manual, together with the operating manual, to the customer. Request the customer to keep them on hand for future use, such as for relocating or repairing the unit.

 WARNING	Indicates a potentially or imminently hazardous situation which, if not avoided, could result in death or serious injury.
--	---

 CAUTION	Indicates a potentially hazardous situation that may result in minor or moderate injury or damage to property.
---	--

 WARNING	<p>To avoid getting an electric shock, never touch the electrical components soon after the power supply has been turned off. After turning off the power, always wait 10 minutes or more before you touch the electrical components..</p> <p>Installation of this product must be done by experienced service technicians or professional installers only in accordance with this manual. Installation by non-professional or improper installation of the product might cause serious accidents such as injury, water leakage, electric shock, or fire. If the product is installed in disregard of the instructions in this manual, it will void the manufacturer's warranty.</p> <p>Do not turn on the power until all work has been completed. Turning on the power before the work is completed can cause serious accidents such as an electric shock or a fire.</p> <p>If refrigerant leaks when you are working, ventilate the area. If the leaking refrigerant is exposed to a direct flame, it may produce a toxic gas.</p> <p>Installation must be performed in accordance with regulations, codes, or standards for electrical wiring and equipment in each country, region, or the installation place.</p> <p>Do not use this equipment with air or any other unspecified refrigerant in the refrigerant lines. Excess pressure can cause a rupture.</p> <p>During installation, make sure that the refrigerant pipe is attached firmly before you run the compressor. Do not operate the compressor under the condition of refrigerant piping not attached properly with 2-way or 3-way valve open. This may cause abnormal pressure in the refrigeration cycle that leads to rupture and even injury.</p> <p>When installing or relocating the air conditioner, do not mix gases other than the specified refrigerant (R32) to enter the refrigerant cycle. If air or other gas enters the refrigerant cycle, the pressure inside the cycle will rise to an abnormally high value and cause rupture, injury, etc.</p> <p>For appropriate working of the air conditioner, install it as written in this manual.</p> <p>To connect indoor unit and outdoor unit, or indoor unit and branch box, use air conditioner piping and cables available through your local distributor. This manual describes proper connections using such installation set.</p> <p>Do not modify power cable, use extension cable or branch wiring. Improper use may cause electric shock or fire by poor connection, insufficient insulation or over current.</p> <p>Do not purge the air with refrigerants but use a vacuum pump to vacuum the installation.</p> <p>There is no extra refrigerant in the outdoor unit for air purging.</p> <p>Do not use means to accelerate the defrosting process or to clean, other than those recommended by the manufacturer.</p> <p>The appliance shall be stored in a room without continuously operating ignition sources (for example: open flames, an operating gas appliance or an operating electric heater).</p> <p>Do not pierce or burn.</p> <p>Be aware that refrigerants may not contain an odour.</p> <p>Using the same vacuum pump for different refrigerants may damage the vacuum pump or the unit.</p> <p>Use a clean gauge manifold, vacuum pump and charging hose for R32 or R410A exclusively.</p>
--	--

INSTALLATION MANUAL

For authorized service personnel only.

PART No.9320394004-02

Contents

1. SAFETY PRECAUTIONS.....	1
2. ABOUT THE PRODUCT.....	3
3. SELECTING THE MOUNTING POSITION	4
4. INSTALLATION DIAGRAM.....	5
5. INSTALLATION	5
6. PUMP DOWN.....	7

 WARNING
Do not modify this unit, such as opening a hole in the cabinet.
During the pump-down operation, make sure that the compressor is turned off before you remove the refrigerant piping.
Do not remove the connection pipe while the compressor is in operation with 2 way or 3 way valve open. This may cause abnormal pressure in the refrigeration cycle that leads to rupture and even injury.

 CAUTION
This unit must be installed by qualified personnel with a capacity certification of handling refrigerant fluids. Refer to regulation and laws in use on installation place.
Install the unit by following local codes and regulations in force at the place of installation, and the instructions provided by the manufacturer.
This unit is part of a set constituting an air conditioner. The unit must not be installed alone or be installed with non-authorized device by the manufacturer.
When installing pipes shorter than 3 m, sound of the outdoor unit will be transferred to the indoor unit, which will cause large operating sound or some abnormal sound.
To protect the persons, earth(ground) the unit correctly, and use the power cable combined with an Earth Leakage Circuit Breaker (ELCB).
The units are not explosion proof, and therefore should not be installed in explosive atmosphere.
This unit contains no user-serviceable parts. Always consult experienced service technicians for repairing.
When moving or relocating the air conditioner, consult experienced service technicians for disconnection and reinstallation of the unit.
Children should be monitored to ensure they do not play with the device.
This appliance is not intended for use by persons (including children) with reduced physical, sensory or mental capabilities, or lack of experience and knowledge, unless they have been given supervision or instruction concerning use of the appliance by a person responsible for their safety. Children should be supervised to ensure that they do not play with the appliance.
Do not touch the aluminum fins of heat exchanger built-in the indoor or outdoor unit to avoid personal injury when you install or maintain the unit.
Do not place any other electrical products or household belongings under indoor unit or outdoor unit. Condensation dripping from the unit might get them wet, and may cause damage or malfunction of your property.

Precautions for using R32 refrigerant

The basic installation work procedures are the same as conventional refrigerant (R410A, R22) models.
However, pay careful attention to the following points:

 WARNING
Since the working pressure is 1.6 times higher than that of refrigerant R22 models, some of the piping and installation and service tools are special. (See "2.1. Special tools for R32 (R410A)".)
Especially, when replacing a refrigerant R22 model with a new refrigerant R32 model, always replace the conventional piping and flare nuts with the R32 and R410A piping and flare nuts on the outdoor unit side.
For R32 and R410A, the same flare nut on the outdoor unit side and pipe can be used.
Models that use refrigerant R32 and R410A have a different charging port thread diameter to prevent erroneous charging with refrigerant R22 and for safety. Therefore, check beforehand. [The charging port thread diameter for R32 and R410A is 1/2 inch.]
Be more careful than R22 so that foreign matter (oil, water, etc.) does not enter the piping. Also, when storing the piping, securely seal the opening by pinching, taping, etc. (Handling of R32 is similar to R410A.)



 CAUTION
<p>1. Installation (Space)</p> <ul style="list-style-type: none"> That the installation of pipe-work shall be kept to a minimum. That pipe-work shall be protected from physical damage. That compliance with national gas regulations shall be observed. That mechanical connections shall be accessible for maintenance purposes. In cases that require mechanical ventilation, ventilation openings shall be kept clear of obstruction. When disposing of the product is used, be based on national regulations, properly processed.
<p>2. Servicing</p> <p>2-1. Service personnel</p> <ul style="list-style-type: none"> Any person who is involved with working on or breaking into a refrigerant circuit should hold a current valid certificate from an industry-accredited assessment authority, which authorizes their competence to handle refrigerants safely in accordance with an industry recognised assessment specification. Servicing shall only be performed as recommended by the equipment manufacturer. Maintenance and repair requiring the assistance of other skilled personnel shall be carried out under the supervision of the person competent in the use of flammable refrigerants. Servicing shall be performed only as recommended by the manufacturer.
<p>2-2. Work</p> <ul style="list-style-type: none"> Prior to beginning work on systems containing flammable refrigerants, safety checks are necessary to ensure that the risk of ignition is minimised. For repair to the refrigerating system, the precautions in 2-2 to 2-8 shall be complied with prior to conducting work on the system. Work shall be undertaken under a controlled procedure so as to minimize the risk of a flammable gas or vapour being present while the work is being performed. All maintenance staff and others working in the local area shall be instructed on the nature of work being carried out. Work in confined spaces shall be avoided. The area around the workspace shall be sectioned off. Ensure that the conditions within the area have been made safe by control of flammable material.
<p>2-3. Checking for presence of refrigerant</p> <ul style="list-style-type: none"> The area shall be checked with an appropriate refrigerant detector prior to and during work, to ensure the technician is aware of potentially flammable atmospheres. Ensure that the leak detection equipment being used is suitable for use with flammable refrigerants, i.e. non sparking, adequately sealed or intrinsically safe.
<p>2-4. Presence of fire extinguisher</p> <ul style="list-style-type: none"> If any hot work is to be conducted on the refrigeration equipment or any associated parts, appropriate fire extinguishing equipment shall be available at hand. Have a dry powder or CO₂ fire extinguisher adjacent to the charging area.
<p>2-5. No ignition sources</p> <ul style="list-style-type: none"> No person carrying out work in relation to a refrigeration system which involves exposing any pipe work that contains or has contained flammable refrigerant shall use any sources of ignition in such a manner that it may lead to the risk of fire or explosion. All possible ignition sources, including cigarette smoking, should be kept sufficiently far away from the site of installation, repairing, removing and disposal, during which flammable refrigerant can possibly be released to the surrounding space. Prior to work taking place, the area around the equipment is to be surveyed to make sure that there are no flammable hazards or ignition risks. "No Smoking" signs shall be displayed.
<p>2-6. Ventilated area</p> <ul style="list-style-type: none"> Ensure that the area is in the open or that it is adequately ventilated before breaking into the system or conducting any hot work. A degree of ventilation shall continue during the period that the work is carried out. The ventilation should safely disperse any released refrigerant and preferably expel it externally into the atmosphere.
<p>2-7. Checks to the refrigeration equipment</p> <ul style="list-style-type: none"> Where electrical components are being changed, they shall be fit for the purpose and to the correct specification. At all times the manufacturer's maintenance and service guidelines shall be followed. If in doubt consult the manufacturer's technical department for assistance. The following checks shall be applied to installations using flammable refrigerants. <ul style="list-style-type: none"> The charge size is in accordance with the room size within which the refrigerant containing parts are installed. The ventilation machinery and outlets are operating adequately and are not obstructed. If an indirect refrigerating circuit is being used, the secondary circuit shall be checked for the presence of refrigerant. Marking to the equipment continues to be visible and legible. Markings and signs that are illegible shall be corrected. Refrigeration pipe or components are installed in a position where they are unlikely to be exposed to any substance which may corrode refrigerant containing components, unless the components are constructed of materials which are inherently resistant to being corroded or are suitably protected against being so corroded.

<p>2-8. Checks to electrical devices</p> <ul style="list-style-type: none"> Repair and maintenance to electrical components shall include initial safety checks and component inspection procedures. If a fault exists that could compromise safety, then no electrical supply shall be connected to the circuit until it is satisfactorily dealt with. If the fault cannot be corrected immediately but it is necessary to continue operation, an adequate temporary solution shall be used. This shall be reported to the owner of the equipment so all parties are advised. Initial safety checks shall include. <ul style="list-style-type: none"> That capacitors are discharged: this shall be done in a safe manner to avoid possibility of sparking. That there no live electrical components and wiring are exposed while charging, recovering or purging the system. That there is continuity of earth bonding.
<p>3. Repairs to sealed components</p> <ul style="list-style-type: none"> During repairs to sealed components, all electrical supplies shall be disconnected from the equipment being worked upon prior to any removal of sealed covers, etc. If it is absolutely necessary to have an electrical supply to equipment during servicing, then a permanently operating form of leak detection shall be located at the most critical point to warn of a potentially hazardous situation. Particular attention shall be paid to the following to ensure that by working on electrical components, the casing is not altered in such a way that the level of protection is affected. <ul style="list-style-type: none"> This shall include damage to cables, excessive number of connections, terminals not made to original specification, damage to seals, incorrect fitting of glands, etc. Ensure that apparatus is mounted securely. Ensure that seals or sealing materials have not degraded such that they no longer serve the purpose of preventing the ingress of flammable atmospheres. Replacement parts shall be in accordance with the manufacturer's specifications. <p>NOTE: The use of silicon sealant may inhibit the effectiveness of some types of leak detection equipment. Intrinsically safe components do not have to be isolated prior to working on them.</p>
<p>4. Repair to intrinsically safe components</p> <ul style="list-style-type: none"> Do not apply any permanent inductive or capacitance loads to the circuit without ensuring that this will not exceed the permissible voltage and current permitted for the equipment in use. Intrinsically safe components are the only types that can be worked on while live in the presence of a flammable atmosphere. The test apparatus shall be at the correct rating. Replace components only with parts specified by the manufacturer. Other parts may result in the ignition of refrigerant in the atmosphere from a leak.
<p>5. Cabling</p> <ul style="list-style-type: none"> Check that cabling will not be subject to wear, corrosion, excessive pressure, vibration, sharp edges or any other adverse environmental effects. The check shall also take into account the effects of aging or continual vibration from sources such as compressors or fans.
<p>6. Detection of flammable refrigerants</p> <ul style="list-style-type: none"> Under no circumstances shall potential sources of ignition be used in the searching for or detection of refrigerant leaks. A halide torch (or any other detector using a naked flame) shall not be used.
<p>7. Leak detection methods</p> <ul style="list-style-type: none"> Electronic leak detectors shall be used to detect flammable refrigerants, but the sensitivity may not be adequate, or may need re-calibration. (Detection equipment shall be calibrated in a refrigerant-free area.) Ensure that the detector is not a potential source of ignition and is suitable for the refrigerant used. Leak detection equipment shall be set at a percentage of the LFL of the refrigerant and shall be calibrated to the refrigerant employed and the appropriate percentage of gas (25 % maximum) is confirmed. Leak detection fluids are suitable for use with most refrigerants but the use of detergents containing chlorine shall be avoided as the chlorine may react with the refrigerant and corrode the copper pipe-work. If a leak is suspected, all naked flames shall be removed/extinguished. If a leakage of refrigerant is found which requires brazing, all of the refrigerant shall be recovered from the system, or isolated (by means of shut off valves) in a part of the system remote from the leak. Oxygen free nitrogen (OFN) shall then be purged through the system both before and during the brazing process.



8. Removal and evacuation

- When breaking into the refrigerant circuit to make repairs – or for any other purpose – conventional procedures shall be used. However, it is important that best practice is followed since flammability is a consideration.

The following procedure shall be adhered to:

- remove refrigerant
 - purge the circuit with inert gas
 - evacuate
 - purge again with inert gas
 - open the circuit by cutting or brazing
- The refrigerant charge shall be recovered into the correct recovery cylinders.
 - The system shall be "flushed" with OFN to render the unit safe.
 - This process may need to be repeated several times.
 - Compressed air or oxygen shall not be used for this task.
 - Flushing shall be achieved by breaking the vacuum in the system with OFN and continuing to fill until the working pressure is achieved, then venting to atmosphere, and finally pulling down to a vacuum.
 - This process shall be repeated until no refrigerant is within the system.
 - When the final OFN charge is used, the system shall be vented down to atmospheric pressure to enable work to take place.
 - This operation is absolutely vital if brazing operations on the pipe work are to take place.
 - Ensure that the outlet for the vacuum pump is not close to any ignition sources and there is ventilation available.

9. Charging procedures

- In addition to conventional charging procedures, the following requirements shall be followed.
 - Ensure that contamination of different refrigerants does not occur when using charging equipment.
 - Hoses or lines shall be as short as possible to minimize the amount of refrigerant contained in them.
 - Cylinders shall be kept upright.
 - Ensure that the refrigeration system is earthed prior to charging the system with refrigerant.
 - Label the system when charging is complete (if not already).
 - Extreme care shall be taken not to overfill the refrigeration system.
- Prior to recharging the system it shall be pressure tested with OFN.
- The system shall be leak tested on completion of charging but prior to commissioning.
- A follow up leak test shall be carried out prior to leaving the site.

10. Decommissioning

- Before carrying out this procedure, it is essential that the technician is completely familiar with the equipment and all its details.
- It is recommended good practice that all refrigerants are recovered safely.
- Prior to the task being carried out, an oil and refrigerant sample shall be taken in case analysis is required prior to re-use of reclaimed refrigerant.
- It is essential that electrical power is available before the task is commenced.
 - Become familiar with the equipment and its operation.
 - Isolate system electrically.
 - Before attempting the procedure ensure that:
 - mechanical handling equipment is available, if required, for handling refrigerant cylinders;
 - all personal protective equipment is available and being used correctly;
 - the recovery process is supervised at all times by a competent person;
 - recovery equipment and cylinders conform to the appropriate standards.
 - Pump down refrigerant system, if possible.
 - If a vacuum is not possible, make a manifold so that refrigerant can be removed from various parts of the system.
 - Make sure that cylinder is situated on the scales before recovery takes place.
 - Start the recovery machine and operate in accordance with manufacturer's instructions.
 - Do not overfill cylinders. (No more than 80 % volume liquid charge).
 - Do not exceed the maximum working pressure of the cylinder, even temporarily.
 - When the cylinders have been filled correctly and the process completed, make sure that the cylinders and the equipment are removed from site promptly and all isolation valves on the equipment are closed off.
 - Recovered refrigerant shall not be charged into another refrigeration system unless it has been cleaned and checked.

11. Labelling

- Equipment shall be labelled stating that it has been de-commissioned and emptied of refrigerant.
- The label shall be dated and signed.
- Ensure that there are labels on the equipment stating the equipment contains flammable refrigerant.

12. Recovery

- When removing refrigerant from a system, either for servicing or decommissioning, it is recommended good practice that all refrigerants are removed safely.
- When transferring refrigerant into cylinders, ensure that only appropriate refrigerant recovery cylinders are employed.
- Ensure that the correct number of cylinders for holding the total system charge are available.
- All cylinders to be used are designated for the recovered refrigerant and labelled for that refrigerant (i.e. special cylinders for the recovery of refrigerant).
- Cylinders shall be complete with pressure relief valve and associated shut-off valves in good working order.
- Empty recovery cylinders are evacuated and, if possible, cooled before recovery occurs.
- The recovery equipment shall be in good working order with a set of instructions concerning the equipment that is at hand and shall be suitable for the recovery of flammable refrigerants.
- In addition, a set of calibrated weighing scales shall be available and in good working order.
- Hoses shall be complete with leak-free disconnect couplings and in good condition.
- Before using the recovery machine, check that it is in satisfactory working order, has been properly maintained and that any associated electrical components are sealed to prevent ignition in the event of a refrigerant release. Consult manufacturer if in doubt.
- The recovered refrigerant shall be returned to the refrigerant supplier in the correct recovery cylinder, and the relevant Waste Transfer Note arranged.
- Do not mix refrigerants in recovery units and especially not in cylinders.
- If compressors or compressor oils are to be removed, ensure that they have been evacuated to an acceptable level to make certain that flammable refrigerant does not remain within the lubricant.
- The evacuation process shall be carried out prior to returning the compressor to the suppliers.
- Only electric heating to the compressor body shall be employed to accelerate this process.
- When oil is drained from a system, it shall be carried out safely.

Explanation of symbols displayed on the indoor unit or outdoor unit.

	WARNING	This symbol shows that this equipment uses a flammable refrigerant. If the refrigerant is leaked, together with an external ignition source, there is a possibility of ignition.
	CAUTION	This symbol shows that the Operation Manual should be read carefully.
	CAUTION	This symbol shows that a service personnel should be handling this equipment with reference to the Installation Manual.
	CAUTION	This symbol shows that there is information included in the Operation Manual and/or Installation Manual.

2. ABOUT THIS PRODUCT

2.1. Special tools for R32 (R410A)

Tool name	Change from R22 to R32(R410A)
Gauge manifold	Pressure is high and cannot be measured with a conventional (R22) gauge. To prevent erroneous mixing of other refrigerants, the diameter of each port has been changed. It is recommended to use gauge with seals -0.1 to 5.3 MPa (-1 to 53 bar) for high pressure. -0.1 to 3.8 MPa (-1 to 38 bar) for low pressure.
Charge hose	To increase pressure resistance, the hose material and base size were changed.(R32/R410A)
Vacuum pump	A conventional vacuum pump can be used by installing a vacuum pump adapter. (Use of a vacuum pump with a series motor is prohibited.)
Gas leakage detector	Special gas leakage detector for HFC refrigerant R32 or R410A.

Copper pipes

It is necessary to use seamless copper pipes and it is desirable that the amount of residual oil is less than 40 mg/10 m. Do not use copper pipes having a collapsed, deformed or discolored portion (especially on the interior surface). Otherwise, the expansion valve or capillary tube may become blocked with contaminants.

As an air conditioner using R32(R410A) incurs pressure higher than when using R22, it is necessary to choose adequate materials.

Thicknesses of copper pipes used with R32(R410A) are as shown in Table1. Never use copper pipes thinner than 0.8 mm even when it is available on the market.

Thicknesses of Annealed Copper Pipes

Nominal diameter (in.)	Outer diameter (mm)	Thickness (mm)
1/4	6.35	0.80
3/8	9.52	0.80
1/2	12.70	0.80



⚠ WARNING

To install a unit that uses R32 refrigerant, use dedicated tools and piping materials that have been manufactured specifically for R32(R410A) use. Because the pressure of R32 refrigerant is approximately 1.6 times higher than R22, failure to use dedicated piping material or improper installation can cause rupture or injury. Furthermore, it can cause serious accidents such as water leakage, electric shock, or fire.

Do not use a vacuum pump or refrigerant recovery tools with a series motor, since it may ignite.

2.2. Power

⚠ WARNING

Always use a special branch circuit and install a special receptacle to supply power to the room air conditioner.

Use a circuit breaker and receptacle matched to the capacity of the air conditioner.

Install a leakage circuit breaker in accordance with the related laws and regulations and electric company standards.

The circuit breaker is installed in the permanent wiring. Always use a circuit that can trip all the poles of the wiring and has an isolation distance of at least 3 mm between the contacts of each pole.

⚠ CAUTION

The power source capacity must be the sum of the air conditioner current and the current of other electrical appliances. When the current contracted capacity is insufficient, change the contracted capacity.

When the voltage is low and the air conditioner is difficult to start, contact the power company the voltage raised.

2.3. Electric requirement

⚠ CAUTION

Be sure to install a breaker of the specified capacity.

Regulation of cables and breaker differs from each locality, refer in accordance with local rules.

Voltage rating	1 ø 240 V (50 Hz)
Operating range	198-264 V

Cable	Conductor size [mm] ² *1		Type	Remarks
Power supply cable	model 07,09,12	1.5	Type 60245 IEC57	2cable + Earth (Ground), 1ø240V
	model 18	2.5		
	model 22,24	4.0		
Connection cable	model 07,09,12	1.5	Type 60245 IEC57	3cable + Earth (Ground), 1ø240V
	model 18,22,24	1.5-2.5		
Demand control signal transmission cable	0.5-1.5		AS/NZS 5000.2.	Double insulated (Max. length : 30m)

*1 Selected sample: Select the correct cable type and size according to the country or region's regulations.
Max. wire length: Set a length so that the voltage drop is less than 2%. Increase the wire diameter when the wire length is long.

Breaker	Specification ²
Circuit breaker (over current)	model 07,09 Current : 10(A)
	model 12,18 Current : 16(A)
	model 22,24 Current : 20(A)
Earth leakage breaker	Leakage current : 30mA 0.1sec or less ³

*2 Select the appropriate breaker of the described specification according to the national or regional standards.

*3 Select the breaker that enough load current can pass through it.

- Before starting work check that power is not being supplied to all poles of the indoor unit and outdoor unit.
- Install all electrical works in accordance to the national standard.
- Install the disconnect device with a contact gap of at least 3 mm in all poles nearby the units. (Both indoor unit and outdoor unit)
- Install the circuit breaker nearby the units.

2.4. Pipe length

Pipe length	Maximum length	Maximum height (between indoor and outdoor)
model 07,09,12,18KU	20m	15m
model 18 ¹ ,22,24	30m	20m

*1 Except 18KU

⚠ CAUTION

If the units are further apart than the maximum length of the piping is specified, correct operation can not be guaranteed.

The outdoor unit with the refrigerant removed from the packaging is sealed. (Indoor unit, the refrigerant is not sealed.)

2.5. Additional charge

For the additional amount, see the table below.

Additional refrigerant	Pipe length	20 m	25 m	30 m	Rate
	model 07,09,12,18KU	None	-	-	-
model 18 ¹ ,22,24	None	+100 g	+200 g	+200 g	20 g/m

	Maximum amount of refrigerant charge
model 07,09,12	850 g
model 18KU	1270 g
model 18 ¹ ,22,24	1470 g (1270 g + 200 g)

*1 Except 18KU

2.6. Operating range

Outdoor temperature	Cooling mode		Heating mode
	Dry mode		
model 07,09,12,18KU	10 to 46 °C	-15 to 24 °C	
	model 18 ¹ ,22,24		-10 to 46 °C

*1 Except 18KU

2.7. Accessories

The following installation accessories are supplied.

Use them as required.

Drain pipe*1	Drain cap*1*2	Cable tie	Installation manual
1	3	1	1

*1 : Included only reverse cycle model
*2 : Included only model 18,22,24

One set of following parts are necessary installation of this product.

Name
Connection pipe assembly
Connection cable
Wall pipe
Decorative tape
Vinyl tape
Wall cap
Saddle
Drain hose
Tapping screws
Sealant

3. SELECTING THE MOUNTING POSITION

- Decide the mounting position with the customer as follows.
- Do not set to a place where there is oily smoke, oil is used in the factory, the unit can contact sea breeze, sulfide gases will be generated in the hot spring area, corrosive gases will be generated, animal may urine on the unit and ammonia will be generated and a dusty place.

3.1. Outdoor unit

- (1) If possible, do not install the unit where it will be exposed to direct sunlight. (If necessary, install a blind that does not interfere with the air flow.)
- (2) Do not install the unit where a strong wind blows or where it is very dusty.
- (3) Do not install in an area that has heat sources, vapors, or the risk of leakage or accumulation of flammable gas.
- (4) Do not install the unit where people pass.
- (5) Take you neighbors into consideration so that they are not disturbed by air blowing into their windows or by noise.
- (6) Provide the space shown in figure so that the airflow is not blocked. Also for efficient operation, leave open three of the four directions front, rear, and both sides.
- (7) Install the unit where keep away more than 3 m from the antenna of TV set and Radio.
- (8) Outdoor unit should be set to a place where both drainage and itself will not be affected when heating.



WARNING

Install at a place that can withstand the weight of the outdoor units and install positively so that the units will not topple or fall.

CAUTION

Do not install where there is the danger of combustible gas leakage.
Do not install near heat sources.
If children may approach the unit, take preventive measures so that they cannot reach the unit.

4. INSTALLATION DIAGRAM

[OUTDOOR UNIT]

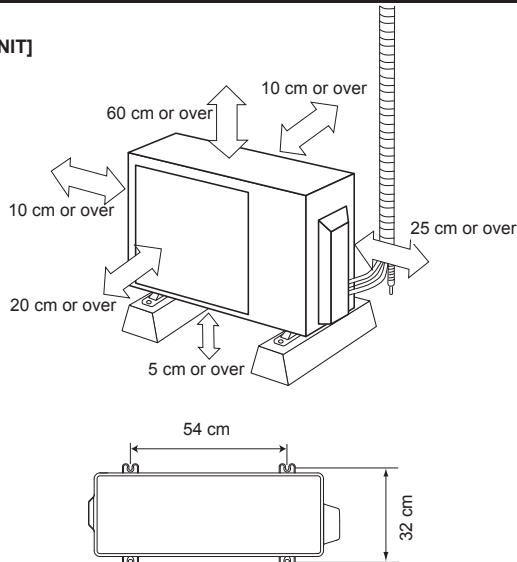

- Do not directly install it on the ground, otherwise it will cause failure.
- To obtain better operation efficiency, when the outdoor unit is installed, be sure to open the front and left side.

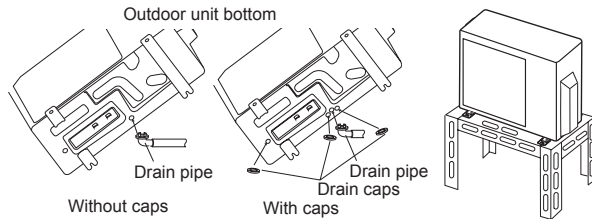

CAUTION

When the outdoor temperature is 0 °C or less, do not use the accessory drain pipe and drain cap. If the drain pipe and drain cap are used, the drain water in the pipe may freeze in extreme cold weather. (Reverse cycle model only)

In the area with heavy snowfall, if the intake and outlet of outdoor unit is blocked with snow, it might become difficult to get warm and it is likely to cause of the breakdown. Please construct a canopy and a pedestal or place the unit on a high stand (local configured).

5. INSTALLATION

5.1. Outdoor unit installation

- Set the unit on a strong stand such as thing made of concrete blocks to minimize shock and vibration.
- Do not set the unit directly on the ground because it will cause trouble.

WARNING

Install the unit where it will not be tilted by more than 5°.

When installing the outdoor unit where it may exposed to strong wind, fasten it securely.

5.2. Switch cover remove

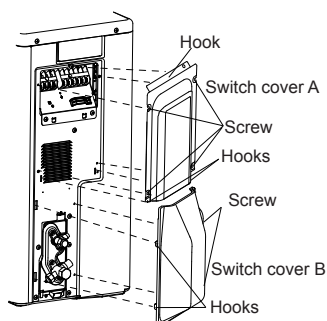

Switch cover A, B removal

- (1) Remove the tapping screws.
- (2) Push downward the Switch cover B.
- (3) Push upward the Switch cover A.

Installing the Switch cover A, B

- (1) After inserting the three hooks of Switch cover A, then push upward.
- (2) After inserting the three hooks of Switch cover B, then push upward, and then tighten the tapping screw.

5.3. HOW TO CONNECT THE WIRE TO THE TERMINALS

- (1) Use crimp-type terminals with insulating sleeves as shown in the figure below to connect to the terminal block.
- (2) Securely crimp the crimp-type terminals to the wires using an appropriate tool so that the wires do not come loose.
- (3) Use the specified wires, connect them securely, and fasten them so that there is no stress placed on the terminals.
- (4) Use an appropriate screwdriver to tighten the terminal screws. Do not use a screwdriver that is too small, otherwise, the screw heads may be damaged and prevent the screws from being properly tightened.
- (5) Do not tighten the terminal screws too much, otherwise, the screws may break.
- (6) See the table below for the terminal screw tightening torques.

Tightening torque

M3.5 screw	0.8 to 1.0 N · m
M4 screw	1.2 to 1.8 N · m
M5 screw	2.0 to 3.0 N · m

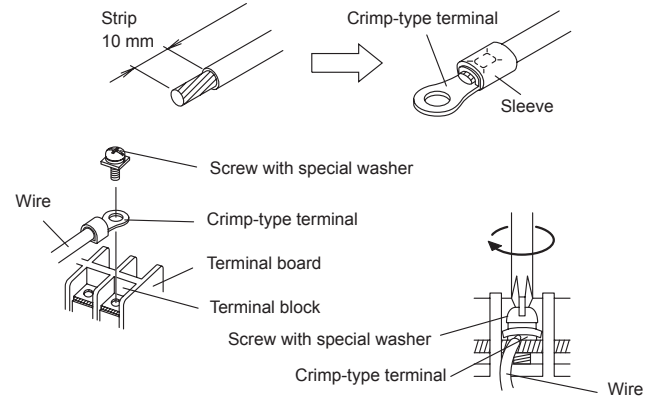

CAUTION

Match the terminal block numbers and connection cable colors with those of the outdoor unit or branch box. Incorrect wiring may cause a fire..

Connect the connection cables firmly to the terminal block. Imperfect installation may cause a fire.

When fixing the connection cable with the cable clamp, always fasten the cable at the plastic jacket portion, but not at the insulator portion. If the insulator is chafed, electric leakage may occur.

Do not use an earth screw for an external connector. Only use for interconnection between two units.

Be careful not to generate a spark as follows for using a flammable refrigerant.

- Do not remove the fuse while power is on.
- Do not disconnect plug from the wall outlet and the wiring while the power is on.
- It is recommended to position the outlet connection in a high position. Place the cords so that they do not get tangled.

Confirm the indoor unit model name before connecting. If the indoor unit is not R32 compatible, error signal will be displayed, and the unit will be inoperable.

5.4. Outdoor unit wiring

- (1) Remove the outdoor unit Switch cover A, B.
- (2) Remove the outdoor unit cable clamp.
- (3) Bend the end of the cable as shown in the figure.
- (4) Connect the end of the connection cable fully into the terminal block.
- (5) Fasten the sheath with a cable clamp.
- (6) Fasten the sheath with a cable tie. (Demand control)
- (7) Install the Switch cover A, B.

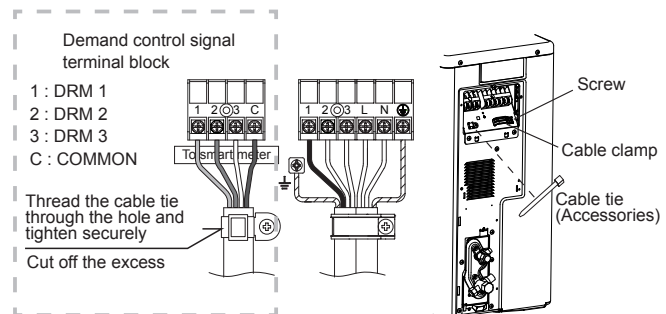

CONNECTION DIAGRAMS

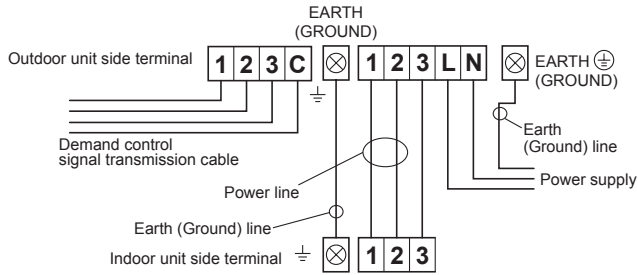

CONNECTION CABLE PREPARATION

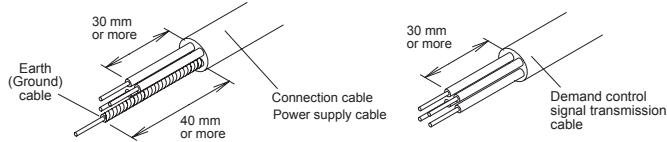

CONNECTION CABLE WIRING

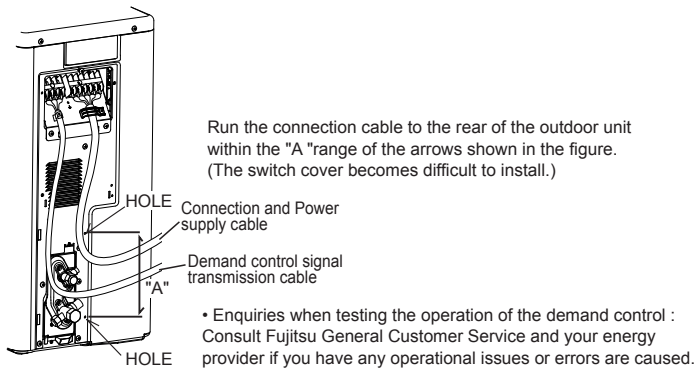

CAUTION

Route the demand control signal transmission cable away from the power supply cable. Adjacent wiring of those cables may lead the product malfunctions caused by generated noise.

5.5. Connecting the piping

CONNECTION

- Install the outdoor unit wall cap (supplied with the optional installation set or procured at the site) to the wall pipe.
- Connect the outdoor unit and indoor unit piping.
- After matching the center of the flare surface and tightening the nut hand tight, tighten the nut to the specified tightening torque with a torque wrench. (Table 1)

FLARING

- Cut the connection pipe to the necessary length with a pipe cutter.
- Hold the pipe downward so that cuttings will not enter the pipe and remove the burrs.
- Insert the flare nut onto the pipe and flare the pipe with a flaring tool.

Insert the flare nut (always use the flare nut attached to the indoor and outdoor units respectively) onto the pipe and perform the flare processing with a flare tool.

Use the special R410A flare tool, or the R22 flare tool.

When using the conventional flare tool, always use an allowance adjustment gauge and secure the A dimension shown in table 2.

Check if [L] is flared uniformly and is not cracked or scratched.

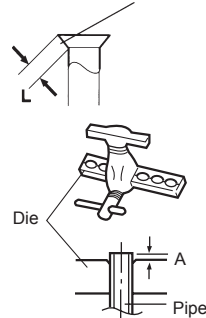

BENDING PIPES

- When bending the pipe, be careful not to crush it.
- To prevent breaking of the pipe, avoid sharp bends. Bend the pipe with a radius of curvature of 70 mm or over.
- If the copper pipe is bent the pipe or pulled to often, it will become stiff. Do not bend the pipes more than three times at one place.

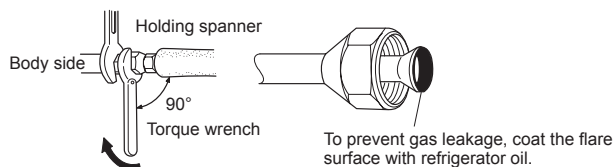

Table 1 Flare nut tightening torque

Flare nut	Diameter (mm) x Torque (N · m)
6.35 mm dia.	17 x 16 ~ 18
9.52 mm dia.	22 x 32 ~ 42
12.70 mm dia.	26 x 49 ~ 61

Table 2 Pipe outside diameter

Pipe outside diameter	A (mm)		
	Flare tool for R32 or R410A, clutch type	R22 Flaring tool	
		Clutch type	Wing nut type
ø 6.35 mm (1/4")	0 to 0.5	1.0 to 1.5	1.5 to 2.0
ø 9.52 mm (3/8")	0 to 0.5	1.0 to 1.5	1.5 to 2.0
ø 12.70 mm (1/2")	0 to 0.5	1.0 to 1.5	1.5 to 2.0

CAUTION

Fasten a flare nut with a torque wrench as instructed in this manual. If fastened too tight, the flare nut may be broken after a long period of time and cause a leakage of refrigerant.

5.6. Air purge

Always use a vacuum pump to purge the air.

Refrigerant for purging the air is not charged in the outdoor unit at the factory.

Close the high pressure side valve of the gauge manifold fully and do not operate it during the following work.

CAUTION

Refrigerant must not be discharged into atmosphere.

After connecting the piping, check the joints for gas leakage with gas leak detector.

- Check if the piping connections are secure.
- Check that the stems of 2-way valve and 3-way valve are closed fully.
- Connect the gauge manifold charge hose to the charging port of the 3-way valve (side with the projection for pushing in the valve core).
- Open the low pressure side valve of the gauge manifold fully.
- Operate the vacuum pump and start pump down.
- Slowly loosen the flare nut of the 3-way valve and check if air enters, then retighten the flare nut.
(When the flare nut is loosened the operating sound of the vacuum pump changes and the reading of the compound pressure gauge goes from minus to zero.)
- Pump down the system for at least 15 minutes, then check if the compound pressure gauge reads -0.1 MPa (-76 cmHg, -1 bar).
- At the end of pump down, close the low pressure side gauge of the gauge manifold fully and stop the vacuum pump.
- Slowly loosen the valve stem of the 3-way valve. When the compound pressure gauge reading reaches 0.1-0.2 MPa, retighten the valve stem and disconnect the charge hose from the 3-way valve charging port.
(If the stem of the 3-way valve is opened fully before the charge hose is disconnected, it may be difficult to disconnect the charge hose.)
- Fully open the valve stems of the 2-way valve and 3-way valve using a hexagon wrench. (After the valve stem begins to turn, turn it with a torque of less than 2.9 N · m until it stops turning.)
- Firmly tighten the 2-way valve and 3-way valve blank cap and the charging port cap.

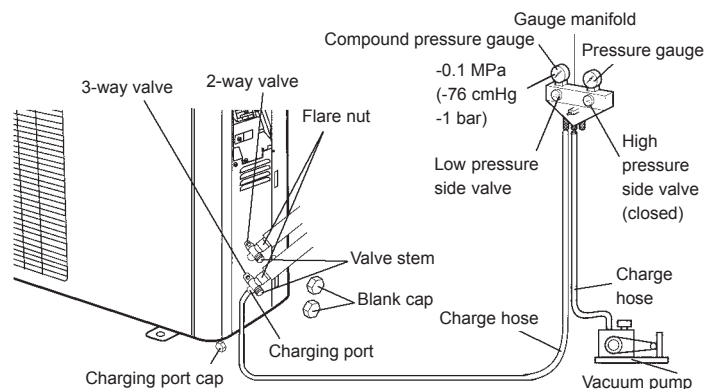

	Tightening torque
Blank cap (1/4 in.)	20.0 to 25.0 N · m
Blank cap (3/8 in.)	20.0 to 25.0 N · m
Blank cap (1/2 in.)	28.0 to 32.0 N · m
Charging port cap	12.5 to 16.0 N · m



5.7. TEST RUN

- Perform test operation and check items below.
- For the test operation method, refer to the operating manual.
- The outdoor unit, may not operate, depending on the room temperature. In this case, keep on pressing the MANUAL AUTO button of the indoor unit for more than 10 seconds. The operation indicator lamp and timer indicator lamp will begin to flash simultaneously during cooling test run. Then, heating test run will begin in about three minutes when HEAT is selected by the remote control operation. (Please follow the operating manual for remote control operation.)
- To end test operation, keep on pressing the MANUAL AUTO button of the indoor unit for more than 3 seconds.
(When the air conditioner is run by pressing the MANUAL AUTO button, the OPERATION indicator lamp and TIMER indicator lamp of the indoor unit will simultaneously flash slowly.)

OUTDOOR UNIT

- (1) Is there any abnormal noise and vibration during operation?
- (2) Will noise, wind, or drain water from the unit disturb the neighbors?
- (3) Is there any gas leakage?

6. PUMP DOWN

6.1. Pump down

PUMP DOWN OPERATION (FORCED COOLING OPERATION)

To avoid discharging refrigerant into the atmosphere at the time of relocation or disposal, recover refrigerant by doing the forced cooling operation according to the following procedure.

- (1) Conduct preliminary operation for 5 to 10 minutes using the forced cooling operation.
Start the forced cooling operation. Keep on pressing the MANUAL AUTO button of the indoor unit for more than 10 seconds. The operation indicator lamp and timer indicator lamp will begin to flash simultaneously during test run. (The forced cooling operation cannot start if the MANUAL AUTO button is not kept on pressing for more than 10 seconds.)
- (2) Close the valve stem of 2-way valve completely.
- (3) Continue the forced cooling operation for 2 to 3 minutes, then close all the valve stems on the 3-way valves
- (4) Stop the operation.
 - Press the START/STOP button of the remote controller to stop the operation.
 - Press the MANUAL AUTO button when stopping the operation from the indoor unit side.(It is not necessary to press down for more than 10 seconds.)

CAUTION

Please check the refrigerant circuit for any leaks before starting the pump down operation.
Do not proceed with the pump down operation if there is no refrigerant left in the circuit due to bent or broken piping
During the pump down operation, be sure to turn off the compressor before removing the refrigerant piping.

